

# CeF<sub>3</sub> Fullerene-like Nanoparticles: Synthesis, Upconversion Properties and Application in Photocatalysis Reduction of CO<sub>2</sub>

Wenqian Hou<sup>\*</sup>, Jun Fan<sup>\*</sup>, Xiaoyun Hu<sup>\*\*</sup>, Enzhou Liu<sup>\*</sup>, Fen Wu<sup>\*</sup>,

Yuhao Yang<sup>\*</sup>, Limin Kang<sup>\*</sup>, Qian Zhang<sup>\*</sup>, Xiao Sun<sup>\*\*</sup>

<sup>\*</sup>School of Chemical Engineering, Northwest University, No. 229  
Taibai North Road, Xi'an, Shannxi, 710069, P. R. China, fanjun@nwu.edu.cn

<sup>\*\*</sup>Department of Physics, Northwest University, No. 229  
Taibai North Road, Xi'an, Shannxi, 710069, P. R. China, hxy3275@nwu.edu.cn

## ABSTRACT

The hexagonal phase CeF<sub>3</sub> particles with fullerene-like structure were synthesized using the microwave-assisted hydrothermal method (M-H). The fluorescence spectrum (PL) showed that the sample could emit light of 304 nm and 324 nm after excited by light of 524 nm, 554 nm, 780 nm and 850 nm, which could achieve a large range of energy upconversion. The up-conversion luminescence mechanism of CeF<sub>3</sub> was proposed to a multi-photon simultaneous absorption and emission, and the formation mechanism of the hollow structure was supposedly an Ostwald Ripening process. Moreover, the sample was composited with TiO<sub>2</sub> to initiate a photocatalytic reduction of CO<sub>2</sub> experimental under visible light ( $\lambda > 515$  nm).

**Keywords:** Fullerene-like CeF<sub>3</sub>, nanoparticles, upconversion luminescence, TiO<sub>2</sub>/CeF<sub>3</sub> composite, catalytic reduction of CO<sub>2</sub>

## 1 INTRODUCTION

As one of rare-earth fluoride, CeF<sub>3</sub> exhibits good luminescence property, lower phonon-energy and special lamellar structure. So it is regarded as a most promising candidate for the materials in high-energy physics, biomarker, and lubricant<sup>[1-3]</sup>. However, CeF<sub>3</sub> was rarely considered as an up-converting material in the past years because Ce<sup>3+</sup> is lack of corresponding energy levels in visible light or near infrared area. Recently, Qiu et. al, have demonstrated the up-converting luminescence of Ce<sup>3+</sup> doped in different host material excited by simultaneous absorption of three infrared photons using an infrared femtosecond laser<sup>[4-6]</sup>. This discovering suggest that Ce<sup>3+</sup> doped compounds can be good candidates for near-infrared to ultraviolet up-converting Phosphor. Compared with doped materials, the molar concentration of Ce<sup>3+</sup> can be 100% in CeF<sub>3</sub> crystals, and the CeF<sub>3</sub> is also an excellent ground host material, its' luminous performance worth studying.

Furthermore, as reported by literature<sup>[7]</sup>, the shapes of the materials can influence the properties of CeF<sub>3</sub> with nano size and lead to different application. Among various nanostructures, fullerene-like structure (IF) with the hollow cavities inside have attracted increasing attention because of their novel application value. Currently, This hollow CeF<sub>3</sub> can be prepared by using hydrothermal method<sup>[8]</sup> or introducing F to a classical Belousov-Zhabotinsky (BZ) oscillating reaction in the bromate-citric acid-Ce(IV) - H<sub>2</sub>SO<sub>4</sub> system<sup>[9]</sup>. In this paper, IF CeF<sub>3</sub> with up-conversion luminescence property was prepared successfully based on the microwave-assisted hydrothermal treatment. Moreover, anatase TiO<sub>2</sub> was synthesized on the CeF<sub>3</sub> surfaces by using microwave-assisted alcohol-thermal method to prepare the IF CeF<sub>3</sub>/TiO<sub>2</sub> composite. Then the IF CeF<sub>3</sub>/TiO<sub>2</sub> was used in photocatalytic reduction of CO<sub>2</sub> experimental and was proved to exhibit visible-light catalytic activity.

## 2 EXPERIMENTAL SECTION

### 2.1 Preparation

In a typical procedure, 1 mmol Ce(NO<sub>3</sub>)<sub>3</sub>·6H<sub>2</sub>O was dissolved in 15 mL distilled water, then 15 mL of aqueous containing 9 mmol NH<sub>4</sub>F was dripped into the solution under stirring. After additional agitation for 30 min, the suspension was transferred into a Teflon-lined vessel then experienced an MH treatments for 30 min at 180 °C. As the reaction system was cooled to room temperature naturally, the precipitates were separated by centrifugation, washed with deionized water and ethanol respectively, then dried in air at 60 °C for 12 h to obtain the IF CeF<sub>3</sub> nanoparticles.

When prepare the IF CeF<sub>3</sub>/TiO<sub>2</sub> composite, 0.4g IF CeF<sub>3</sub> obtained above was dispersion in a solution with 7.64 mL ethanol and 7.83 mL acetic acid by stirring and ultrasonic mixing to prepare a turbid liquor. Then another solution with 6.67 mL butyl titanate and 7.64 mL ethanol was injected into the turbid liquor with a rate of 0.05 mL/ s under stirring. The final mixed liquor experienced same MH processing, centrifugal washing (only used ethanol) and drying processing as the preparation of IF CeF<sub>3</sub>. The

dry powder was annealed in 300 °C for 3 h and 450 °C for 30min with the heating rate of 5 °C/ min to obtain the IF CeF<sub>3</sub>/TiO<sub>2</sub> composite. Pure TiO<sub>2</sub> could be synthesized as this process was repeated without adding IF CeF<sub>3</sub>.

## 2.2 Characterization.

The Crystalline phase of samples was identified by X-ray diffraction (XRD, Bruker D8, Cu K $\alpha$ ,  $\lambda=0.15406$  nm). The general morphologies were observed using a field-emission scanning electron microscope (SEM, JSM-6390A) with energy-dispersive X-ray (EDX) analysis, and a transmission electron microscope (TEM, JEM-100SX) with selected area electron diffraction (SADE) analysis. The Photoluminescence spectral (PL) were measured on a fluorescence spectrophotometer (Hitachi F-7000, equipped with a 150 W xenon lamp as the excitation source).

## 3 RESULTS AND DISCUSSION

### 3.1 Structure and Morphology

Fig.1 shows XRD patterns of the as-prepared IF CeF<sub>3</sub>, TiO<sub>2</sub> and IF CeF<sub>3</sub>/TiO<sub>2</sub> composite samples. The high and sharp peaks in the patterns indicate that all of the samples are well crystallized. According to the JCPDS standard, the IF CeF<sub>3</sub> and TiO<sub>2</sub> can be easily indexed as pure hexagonal phase CeF<sub>3</sub> (JCPDS No.38-0452, Fluocerite ) and pure Anatase TiO<sub>2</sub> (JCPDS No.21-1272, Fluocerite ) respectively. The pattern of CeF<sub>3</sub>/TiO<sub>2</sub> composite includes both the diffraction peaks of IF CeF<sub>3</sub> and TiO<sub>2</sub> without other impurity peak, that illustrate the compounding would not change the crystalline phase and chemical properties of TiO<sub>2</sub> or IF CeF<sub>3</sub>. Scherrer crystallite sizes of IF CeF<sub>3</sub> and TiO<sub>2</sub> in their pure substance are calculated to 20.9 and 24.4 nm, while their sizes in IF CeF<sub>3</sub>/TiO<sub>2</sub> composite are 19.7 and 37.2 nm.

The morphology of the as-prepared IF CeF<sub>3</sub>, TiO<sub>2</sub> and IF CeF<sub>3</sub>/TiO<sub>2</sub> composite is illustrated in Fig.2. The TEM image of IF CeF<sub>3</sub> sample (Fig.2A, 2B) shows the nano hollow sphere-like or hollow rod-like CeF<sub>3</sub> with good dispersibility. The sphere-like nanoparticles have a diameter of about 30 nm, while the rod-like nanoparticles have a length of 30 nm and a diameter of about 15 nm. The EDXA analysis indicates that the mole fraction of Ce and F in this IF CeF<sub>3</sub> are 75.24% and 24.76%, which is in agreement with a molar ratio of 1:3. The SADE pattern (Fig. 2C) of the sample, obtained from a single hollow nanoparticle reveals polycrystallinity. It can be supposed that the hollow structures could result from the Ostwald ripening process. Fig.2D, 2E are the SEM images of the IF CeF<sub>3</sub> and TiO<sub>2</sub> respectively. It can be observed easily that the IF CeF<sub>3</sub> sample is composed with many uniform nano particles, but the TiO<sub>2</sub> sample is composed with big agglomerations of different size. In SEM image of IF CeF<sub>3</sub>/TiO<sub>2</sub> composite (Fig.2F), the feature of IF CeF<sub>3</sub> is unseen, which could be due to that CeF<sub>3</sub> is well intermixed or coated with TiO<sub>2</sub>.

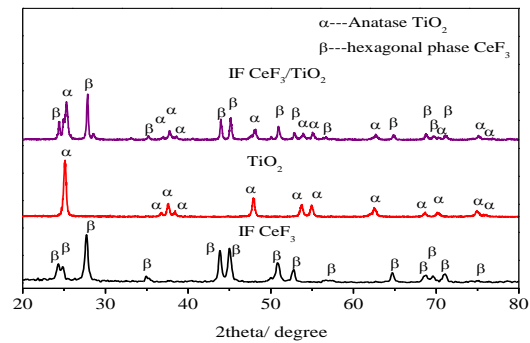

Figure 1. XRD patterns of IF CeF<sub>3</sub>, TiO<sub>2</sub> and IF CeF<sub>3</sub>/TiO<sub>2</sub> composite

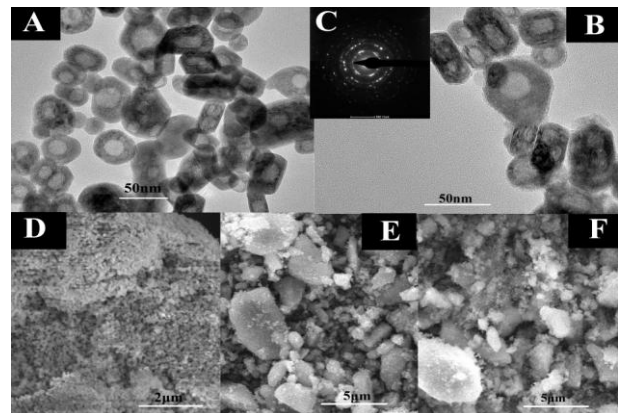
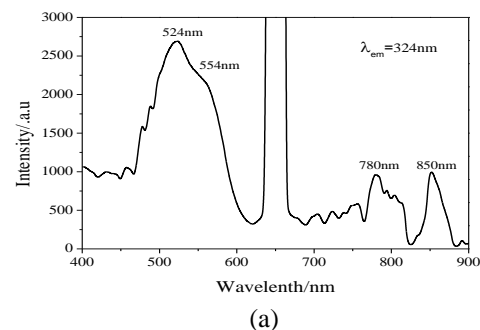

Figure 2. TEM images (A, B), SADE pattern(C), SEM image(D) of IF CeF<sub>3</sub> sample and SEM images of TiO<sub>2</sub> (E), IF CeF<sub>3</sub>/TiO<sub>2</sub> sample (F).

### 3.2 Up-Conversion Luminescence Properties

Figure 3 show the up-conversion luminescence excitation and emission spectra of the IF CeF<sub>3</sub> sample. It can be observed that under the excitation of 524 nm, 554 nm, 780 nm and 850 nm, the IF CeF<sub>3</sub> can emit UV light of 304 nm and 324 nm. The luminescent intensity weakened with the increasing in wavelength of exciting light. This process can achieve large scope of energy up-conversion from visible and near-infrared light to UV light.



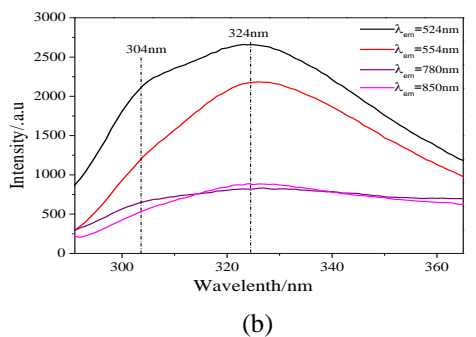

Figure 3. Up-conversion luminescence excitation (a) and emission (b) spectra of the IF CeF<sub>3</sub> sample

### 3.3 Photocatalytic Properties

The visible-light catalytic activity of samples was measured by photocatalytic reduction of CO<sub>2</sub> with water under the light which wavelength greater than 515 nm. Figure 4 shows the yield-time changes of major product methanol in this reaction when used different samples as catalytic respectively. It can be seen clearly that IF CeF<sub>3</sub>/TiO<sub>2</sub> composite has obvious activity while IF CeF<sub>3</sub> or TiO<sub>2</sub> are not. The corresponding methanol yield increases quickly and reaches to 169.23 μmol/ g-cat at 3h when the CeF<sub>3</sub>/TiO<sub>2</sub> composite is used as catalytic. The result illustrate that the visible light (λ>515 nm) catalytic activity of TiO<sub>2</sub> could be initiated under the existence of CeF<sub>3</sub>, and the spectral response range of TiO<sub>2</sub> is extend. That should due to that TiO<sub>2</sub> can absorb the UV light converted from visible light by IF CeF<sub>3</sub> to exhibits a catalytic effect.

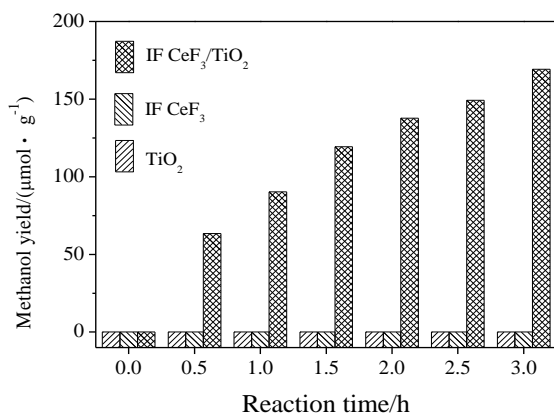

Figure 4. Methanol yield of photocatalytic reaction of CO<sub>2</sub> under visible light irradiation (λ>515 nm) using the IF CeF<sub>3</sub>, TiO<sub>2</sub>, and IF CeF<sub>3</sub>/TiO<sub>2</sub> as catalyst respectively.

### 3.4 The Mechanism of Up-Conversion Luminescence

In order to research the up-conversion process, the down-shifting luminescence excitation and emission spectra of the IF CeF<sub>3</sub> sample also be detected (Figure 4). The result shows that the IF CeF<sub>3</sub> can also emit light of 304 nm and 324 nm after excited by ultraviolet light of 260 nm and 280 nm. That is attributed to electrons' transition from the <sup>2</sup>F<sub>5/2</sub> ground state to different components of the 5d states in Ce<sup>3+</sup> split by the crystal field. The phenomena demonstrate obvious properties of broad-band absorption and emission, which is in consistence with most references<sup>[10-12]</sup>.

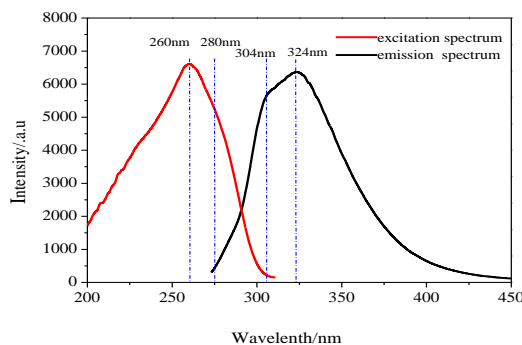

Figure 5. Down-shifting luminescence excitation spectra and emission spectra of the IF CeF<sub>3</sub>

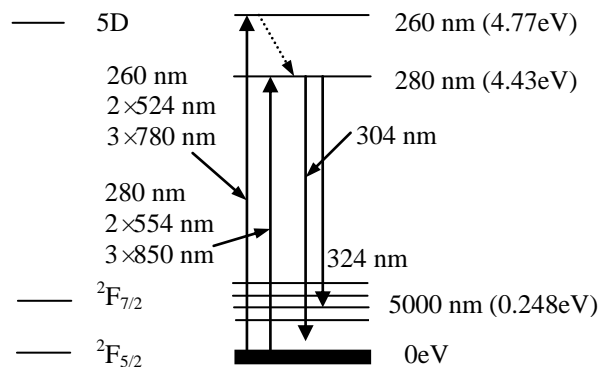

Figure 6. Up-conversion luminescence process of the IF CeF<sub>3</sub> sample

It is apparent that the exciting and emitting peak of up-conversion are similar to that of the down-shifting in shape and position, can be indicated to the transition of the Ce<sup>3+</sup> electronic between 5d and 4f level. Through analyzing the exciting energy of 260 nm is twice and three times as much as the excitation light of 524 nm, 780 nm respectively. Meanwhile, the lights of 524 nm, 554 nm, 780 nm, 850 nm were not found in the emission spectra, it is supposed that there were not corresponding intermediate levels between 4F and 5D level. According to above analysis, the luminescence mechanism should be deduced to a multi-photon simultaneous absorption. This phenomenon could

be considered that more than one photon are absorbed at the same time, which result in electron-transitions from the initial state to final state, just through the hypothetical intermediate state.

The concrete process is showed in figure 6. At first, the electron located on the ground state ( $^2F_{5/2}$ ) is excited to the energy level of 4.43 eV or 4.77 eV after absorbing two photons of 525 nm or three photons of 780 nm at the same time, then resulting the UV emission of 304 nm or 324 nm after lost some energy reacting with surrounding crystal field.

## 4 CONCLUSION

Fullerene-like nano  $CeF_3$  with up-conversion luminescence property have been successfully fabricated through a facile and effective microwave hydrothermal method. When excited by the light of 524 nm, 554 nm, 780 nm and 850 nm, this IF  $CeF_3$  could emit the light of 304 and 324 nm, the corresponding luminous mechanism could be conjectured as the multi-photon simultaneous absorption luminescence. By using a microwave-assisted alcohol-thermal method and annealing, the  $CeF_3$  was composited with anatase  $TiO_2$  to improve the visible-light catalytic activity of the latter. The result of photocatalytic reduction of  $CO_2$  showed that the  $CeF_3/TiO_2$  composite has an obvious catalytic effect under visible light.

## ACKNOWLEDGEMENTS

This work was supported by the National Natural Science Foundation of China (No.21176199) and the Research Fund for the Doctoral Program of Higher Education (No.20096101110013).

## REFERENCES

- [1] Yu Pei, Xiaofeng Chen, Dongmin Yao, Guohao Ren. The role of  $CeF_3$  in  $LaCl_3$  Scintillation Crystal. Radiation Measurements. 2007, 42(8): 1351-1354.
- [2] Chunxia Li, Jun Yang, Piaoping Yang, Hongzhou Lian, Jun Lin. Hydrothermal Synthesis of Lanthanide Fluorides  $LnF_3$  ( $Ln = La$  to  $Lu$ ) Nano-/Microcrystals with Multiform Structures and Morphologies. Chem. Mater, 2008, 20(13) : 4317-4326.
- [3] Libo Wang, Ming Zhang , Xiaobo Wang, Weimin Liu. The Preparation of  $CeF_3$  Nanocluster Capped with Oleic Acid by Extraction Method and Application to Lithium Grease. Materials Research Bulletin., 2008, 43(8-9): 2220-2227.
- [4] Wang Chen, Peng Mingying, Yang Lüyun, Hu Xiao, Da Ning, Chen Danping, Zhu Congshan, Qiu Jianrong. Upconversion Luminescence of  $Ce^{3+}$  Doped BK7 Glass by Femtosecond Laser Irradiation. Journal of Rare Earths. 2006, 24(6): 754-756.
- [5] Yongjun Dong, Jun Xu, Guoqing Zhou, Guangjun

- Zhao, Mingyin Jie, LuYun Yang, Liangbi Su, Jianrong Qiu, Weiwei Feng, Lihuang lin. Blue Upconversion Luminescence Generation in  $Ce^{3+}:Gd_2SiO_5$  Crystals by Infrared Femtosecond Laser Irradiation. Optics Express. 2006, 14(5): 1899-1904.
- [6] Yongjun Dong, Jun Xu, Guangjun Zhao, Chenfeng Yan, Guoqing Zhou, Liangbi Su, Luyun Yang, Jianrong Qiu, Lihuang Lin, Xiaoyan Liang, Ruxin Li, and Zhizhan Xu, Qiushi Ren. Simultaneous Three-Photon-Excited Violet Upconversion Luminescence of  $Ce^{3+}:Lu_2Si_2O_7$  Single Crystals by Femtosecond Laser Irradiation. Optics Letters. 2006, 31(14):2175-2177.
- [7] Ling Zhu, Qin Li, Xiangdong Liu, et al. Morphological Control and Luminescent Properties of  $CeF_3$  Nanocrystals[J]. Journal of Physical Chemistry C. 2007, V111(16): 5898-5903
- [8] Yang Liu, Yanbao Zhao, Huajuan Luo, Zhishen Wu, Zhijun Zhang. Hydrothermal Synthesis of  $CeF_3$  Nanocrystals and Characterization. Journal of Nanoparticle Research. 2011, 13(5).
- [9] Qiang Wu, Ying Chen, Pei Xiao, Fan Zhang, Xizhang Wang, Zheng Hu. Hydrothermal Synthesis of Cerium Fluoride Hollow Nanostructures in A Controlled Growth. Journal of Physical Chemistry C. 2008, 112(26): 9604-9609.
- [10] Yang Liu, Yanbao Zhao, Huajuan Luo, Zhishen Wu, Zhijun Zhang. Hydrothermal Synthesis of  $CeF_3$  Nanocrystals and Characterization. Journal of Nanoparticle Research. 2011, 13(5).
- [11] K. Klier, P.Novak, A.C. Miller, J.A. Spirko, M.K. Hatalis. Electronic Structure of  $CeF_3$  and  $TbF_3$  by Valence-Band XPS and Theory. Journal of Physics and Chemistry of Solids. 2009. 70(9): 1302-1311.
- [12] C. Dujardin, C. Pedrini, N. Garnier, A. N. Belsky, K. Lebbou, J. M. Ko, T. Fukuda. Spectroscopic Properties of  $CeF_3$  and  $LuF_3$ :  $Ce^{3+}$  Thin Films Grown by Molecular Beam Epitaxy. Optical Materials. 2001, 16(1-2): 69-76.