

Application-specific Molecular Logic Systems

Marek Zgol, R. Glenn Wright, David Adebimpe and Tim Callinan

GMA Industries, Inc., 60 West Street, Suite 203
Annapolis, MD, USA {marek,glenn,david,tim}@gmai.com

ABSTRACT

This paper describes progress in the development efforts for creating organic organic-based molecular equivalents of legacy systems in existing aircraft and aircraft systems. Utilizing the advances in nanoassembly methodologies, including electric field-based manipulation techniques and advanced organic syntheses, we explore the potential for replicating existing aircraft system functions at nanoscale levels. Targeting a specific electronic system provides opportunity for thorough evaluation of the developed devices within a realistic environment, as well as an avenue for addressing the issues related to creating a viable physical interface and components capable of withstanding actual working conditions. Representative examples of the existing aircraft systems were chosen for the retrofit, and particular logic devices are being investigated for the possibility of replicating their functionality with orders-of-magnitude smaller and potentially much more efficient molecular equivalents.

Keywords: carbon nanotubes, molecular electronics, aircraft system retrofit, aircraft legacy systems

1 INTRODUCTION

The cost of developing system upgrades to enhance performance in today's aircraft and aircraft systems and to replace legacy equipment that is obsolete or difficult to maintain continues to increase at an alarming rate. Critical to the cost equation is the amount of physical space dedicated to these systems. Cost increases may be mitigated to some extent by a reduction in the space required to perform the same function through the miniaturization of system components. Space left vacant within legacy systems and within the aircraft itself may be put to use in providing additional functionality to existing systems, or made available for other uses. Examples of this may range from providing additional memory and/or processing capability of existing circuit cards, to replacing a suite of shop or line replaceable units (SRUs/LRUs) with only one SRU or LRU. Also, "dumb" components, such as the aircraft skin or inspection covers, may provide additional functionality through the infusion of sensor or computational elements.

An opportunity exists to utilize advances in nanotechnology to explore the potential for replicating and extending existing aircraft system functions at nanoscale

levels. Through our research, we are assessing the technical feasibility of accomplishing this goal, and identify the technologies likely to provide short-term breakthroughs as well as those that may be suitable for longer-term investigation. Fulfillment of such an opportunity may result in revolutionary new aircraft, extending the useful life of existing aircraft, and weapon system capabilities possessing small dimension and low costs that heretofore could not be imagined.

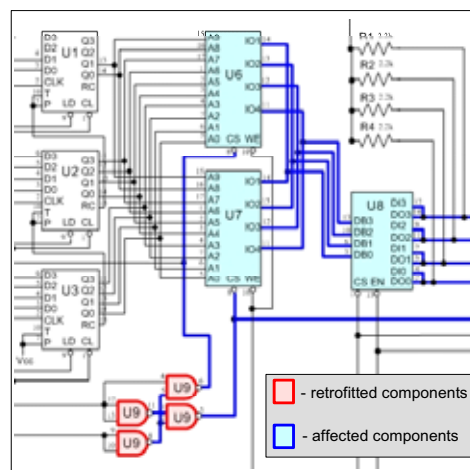

Figure 1: RAM Board Fragment Affected by the Retrofit

2 DESIGN CONSIDERATIONS

By choosing a specific RAM board as the target, we are focusing on replicating the board functionality with a molecular-based logic. Initially, the scope of research is limited to a particular section of the board containing NAND logic gates, as indicated in Figure 1. The NAND gates require negation of the logic output, which means that basic diode-based logic will need to be combined with a type of molecular inverter. We understand that this approach carries substantial risks related to the development of fairly sophisticated molecular electronic structures, however, it provides us with the potential of developing a single device able to replicate every possible logic component, thus far surpassing the payoff of developing AND or OR gates.

Through the addition of the inverter to an AND logic gate architecture, we achieve the required negation of the AND gate output, and the entire system functions as logic NAND gate (Figure 2).

The basic macroscale inverter is accomplished through resistor-transistor logic (RTL) or transistor-transistor logic (TTL). These can be emulated in nanotechnology, as shown by several research groups [1][2][3].

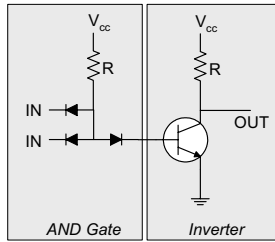

Figure 2: Logic NAND Gate Comprised of an AND Gate and an Inverter

For our design, we chose a single-walled carbon nanotube (SWNT) device analogous to PMOS type FET (Figure 3). An intrinsic p-type nanotube is connected with an external resistor between the ground and source of the device while a bias voltage is applied to the drain.

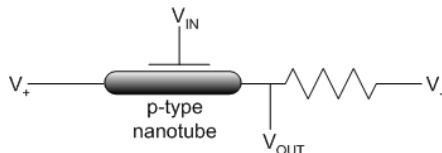

Figure 3: Resistor-Transistor Logic Based Carbon Nanotube Inverter

In the design of the TTL SWNT inverter (Figure 4), p-type and n-type nanotubes were wired in series to create a complementary device (analogous to CMOS FETs). The creation of the n-type side requires direct doping with potassium vapor (an electropositive element) of part of the p-type or a separate p-type nanotube.

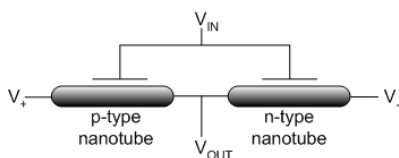

Figure 4: Transistor-Transistor Logic Based Carbon Nanotube Inverter

To utilize the presented inverter architectures, we conceptualized, designed, and fabricated test beds for fabricating and testing the inverter, and formulated appropriately functionalized nanotubes as described in the next sections.

3 EXPERIMENTAL SECTION

3.1 Carbon Nanotube Maneuvering

Previous research by our team in manipulating SWNTs shows that nanotubes gather in areas of high magnetic

fields and align along the magnetic field lines [4]. This technique, called dielectrophoresis, represents an extremely useful tool for nanotube manipulation and is a technique of choice for the formation of the nanotube junction for the inverter preparation. Particles situated between electrodes exhibit frequency dependant behavior. At lower frequencies, particles collect in the regions of high electrical field strength, usually at the tip of electrodes; while at higher frequencies, they are being ‘trapped’ in areas of magnetic minimum. Before fabricating the circuitry, the magnetic fields were modeled using the commercial finite element software ANSOFT. With this software it is possible to determine the electromagnetic intensity and direction as a result of the applied voltage and frequency as well as electrode shape and material. Figure 5 shows the magnetic field direction and intensity forecasted for the PEDOT electrodes.

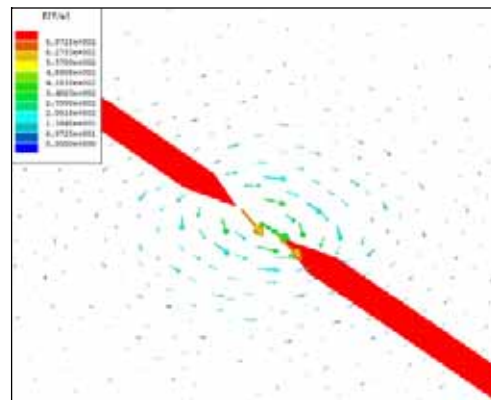

Figure 5: Magnetic Field Direction of Two Electrodes Calculated Using ANSOFT Software

The theoretical model mentioned above served as a basis for conducting lab experiments optimizing the concept of maneuvering small objects within the electric field created with PEDOT and metallic circuitry. Using simple electric field calculations, we realized that to move particles of 1-100 μm in size, a field of 10^4 - 10^5 V/cm is required. To keep the required voltage levels in realistic regime (single volts) while achieving such electric field strength, the electrode spacing needed to be in the neighborhood of 1-10 μm . In practice, it translated into the necessity of finding a patterning method offering a sufficient resolution, which was the focus of our successive research.

3.2 Test Circuitry Material Selection

Experimental and theoretical studies have suggested that the adsorption of an organic molecule by a metal, as in an organic-on-metal interface, results in a lowering of the Fermi level [5]. This lowering, however, leads to the formation a large hole-injection barrier [6]. This lowering of the work function will be complimented by downward shifts in molecular energy levels and will result in a

concomitant increase in the energy difference between the metal Fermi level and the highest occupied molecular orbital (HOMO) of the molecular wire.

We believe that efficient electron transfer can only be optimized through a compatibility of interfacial dipole barriers present at the molecular wire-electrode interface. Such comparability at the interface should result in an interfacial region of well matched, or favorable, orbital hierarchy. This hierarchy may be better achieved with organic electrodes; an organic electrode should enable the formation of smaller hole injection barriers at a contact with a conjugated organic material, as compared to contact with a high work function material.

3.3 Patterning Techniques Evaluation

Based on this assumption, the suitability of known intrinsically conducting organic conjugates, as organic electrodes, was investigated. From our work in this area, poly(3,4-ethylenedioxy)thiophene (PEDOT) was identified as an ideal electrode candidate. A water-borne solution of the conducting polymer PEDOT, in the presence of polystyrene sulphonic acid (PSS) as colloid stabilizer, is commercially available from Bayer AG & Hoechst AG as Baytron® P.

Inkjet printing was the first patterning method tested. A standard thermal inkjet device was used, the only modification to which was replacing the ink in a cartridge with the PEDOT solution. The challenges of the technique lie in modifying the polymers to have similar viscosity and surface properties as the printer ink and in selecting the appropriate printing medium. Using standard transparencies, we were able to print schematics with moderate conductivity of 0.1 S/cm

The line patterning method introduced by MacDiarmid and Hohnholz was also investigated [7]. This technique uses standard office equipment to apply a hydrophobic pattern to a transparency, which serves as a negative of the required circuit. In this method, PEDOT solution modifications, harmful to the polymer conductance, are avoided due to the use of spin-coating technique for the polymer deposition. This method though useful still does not have the resolution required for dielectrophoresis.

Continuing our search for the appropriate patterning method, a technique was conceptualized merging elements of lithography characterized with high spatial resolution and a spin-coating technique offering relatively simple way of depositing the polymer. First, a monolayer of 1,1'-biophenyl-4-thiol (BPT) is treated with a low energy electron beam that locally changes the wetting properties of the material. The deposited PEDOT "sticks" only to the unexposed (hydrophilic) areas of the substrate forming the desired pattern. Substances with different wetting properties can also be used for the method allowing for "positive" image creation and tuning the process resolution.

In parallel to the polymeric circuitry patterning research, studies were performed to test and improve the

processability and efficiency of the polymer. Modifications to PEDOT included the addition of surfactants (Tween-80) to achieve the surface tension characteristics required for inkjet printing. Upon adding N-methyl-pyrrolidone (NMP), it was found that the conductivity of the resulting film increased by three orders of magnitude (10% NMP in PEDOT). Not waiting for the conclusion of the polymer processing and patterning studies, we commenced the SWNT device setup preparations using metallic circuitry.

3.4 Inverter Test Setup

A prototype of a NAND logic gate would not only demonstrate the feasibility of the technology but also constitute a substantial building block for a wide variety of future molecular electronic devices. In preparation for forming single-nanotube inverters based on both TTL and RTL logic, we designed and fabricated appropriate test beds, as presented in Figure 6. We also proved the feasibility of completing the discrete steps leading to forming of such a device.

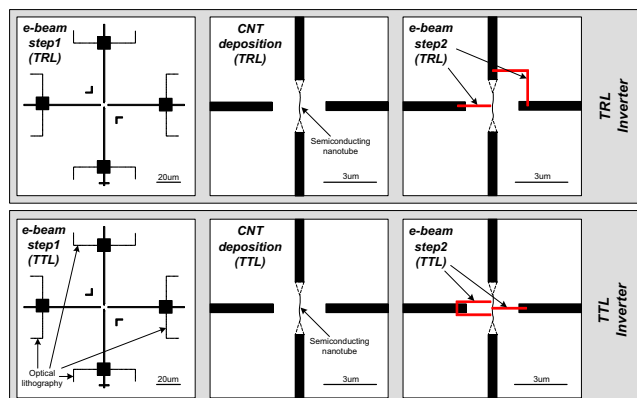

Figure 6: Inverter Test-bed Fabrication Steps

In particular, we demonstrated the ability to untangle carbon nanotube ropes using common organic solvent systems and capacity to effectively control the positioning of those nanotubes on a substrate.

Both designs consist of two separate e-beam steps. The first step is aligned with the photolithography lines on the ZIF connector design. After depositing the nanotubes and finding their location with an AFM, the next e-beam lithography lines are created in alignment with the nanotube positions on the circuit.

3.5 Tailoring the Nanotubes

Nanotubes have been found to have length-dependent, electromagnetic absorbing properties [8]. For example, nanotubes irradiated by 2.5 MeV electrons with different fluences have shown to be resistant to radiation without radiolysis effects [9], and it has been proposed that ropes of SWNTs could serve as efficient beam channeling materials

since a carbon nanotube's large bore (13.8 Å diameter) allows plenty of room for the passage of particle beams [10]. Carbon nanotubes also allow a broadband protection capability because of the thermal nature of non-linear scattering [11]. Phonons dominate thermal transport at all temperatures in carbon materials [12], and since phonon thermal conductivity (k) is roughly $k=C_p v_s l$ (where C_p is the specific heat, v_s is the speed of sound, and l is the mean free path), SWNTs should be ideal for high performance thermal management [13].

The amalgamation of these properties with the extraordinary electronic behavior of the nanotubes, creates a potential not only to fabricate easily-processible, functionalized carbon nanotube moieties for the logic device preparation, but also to form nanotube embedded EMI shielding and heat-dissipating materials for protecting the nanoscale devices from destructive effects of the electromagnetic radiation and excessive heat.

With that in mind, we modified SWNT architectures by fitting them with a series of substituent groups. The substituents allow for adjusting the nanotube characteristics to suit the specific application and also to further extend the structure alternation or to fasten the tubes to specific circuit elements.

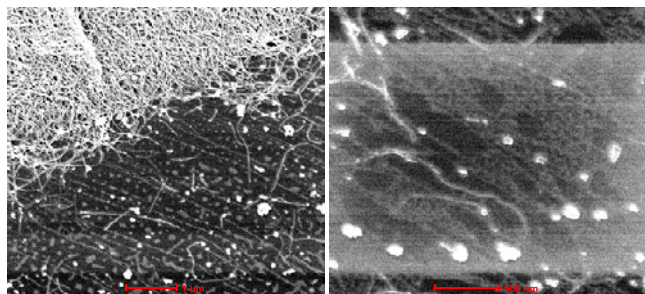

Figure 7: Fluorinated Nanotubes Dispersed in Ethanol

One of the processes used was halogenation, where we applied a variation of a solvent-free method optimized to maximize the control of polyfunctionalization on the nanotubes. When the original solvent-free method of polyfunctionalization was used, as described by James Tour et al. [14], it seemed that the magnitude of functionalization found within the derivatives obtained was low. Unlike Tour and others [15][16], we avoided using DMF as a solvent as we are aware that DMF does not make a good solvent in acidic or basic conditions. Instead, we used a proprietary aprotic solvent system, which is inert to both acidic and basic reaction conditions.

Structural integrity of the functionalized tubes was confirmed with the SEM images presented in Figure 7, and the effectiveness of our synthetic procedures was also reflected in the Raman spectra acquired for each of the derivatives.

The tubes functionalized with our method are readily soluble in a range of common organic solvents, what translates into trouble-free processing procedures and forms the basis for the fabrication of functionalized SWNT devices using dielectrophoresis.

4 ACKNOWLEDGEMENTS

The work presented in this paper was supported by the US Air Force Contract No. F42650-03-P-2753. Portion of the experimental research was performed with the participation of the Nondestructive Evaluation Group at NASA Langley Research Center (Hampton, VA) under MOA No. SAA1-589 and the Surface and Interface Research Group at NIST (Geithersburg, MD) under CRADA No. CN-1871. All opinions expressed are solely those of the authors and do not represent the viewpoint of the US Air Force, NASA, or NIST.

REFERENCES

- [1] V. Derycke et al., Nano Letters, 1 (9) 453, 2001.
- [2] A Bachtold et al., Physica E, 16, 453, 2003.
- [3] A. Liu et al, Appl. Phys. Lett., 79 (20) 3329, 2001.
- [4] P. A. Williams, et al., 2003 Materials Research Soc. Fall Meeting, Boston, MA, December 2003.
- [5] H. Ishii, et al., Adv. Mater. 11, 605, 1999.
- [6] I. G. Hill, et al., Appl. Phys. Lett. 73, 662, 1998.
- [7] D. Hohnholz and A.G. MacDiarmid, Synth. Met., 121, 1327, 2001.
- [8] T. Jeon, et al., J. Korean Phy. Soc. 39, S185, 2001.
- [9] F. Beuneu, et al., Phy. Rev. B, Condensed Mat., 59 (8) 5945, 1999.
- [10] L. A. Gevorgyan et. al., J. Exp. Theo. Phy. Letts., 10, September 1997.
- [11] J. Wei, et. al., Appl. Phys. Letts. 73, 3532, 1998; Phy. Rev. Letts. 82, 2548, 1999.
- [12] L. X. Benedict, S. G. Louie and M. L. Cohen, Solid State Commun., 100, 177, 1996.
- [13] J. Hone, B. Batlogg, Z. Benes, A. T. Johnson, and J. E. Fischer, Science, 289, 1730, 2000.
- [14] Christopher A. Dyke and James M. Tour, J. Am. Chem. Soc., 125 (5), 1156, 2003.
- [15] Bahr, J. L., Tour, J. M., Chem. Mater., 13, 3823, 2001.
- [16] Bahr, J. L., Yang, J., Kosynkin, D. V., Bronikowski, M. J., Smalley, R.E., Tour, J. M., J. Am. Chem. Soc., 123, 6536, 2001.