

# Micromirror Array Design And Simulation

M. Huja and M. Husak, IEEE Member

Czech Technical University in Prague – Faculty of Electrical Engineering  
Department of Microelectronics  
E-mail: husak@feld.cvut.cz

## ABSTRACT

The main objective of the research described is to design optimal principle of micromirror array and its manufacturing technology with maximum penetration of the reflected/non-reflected part of micromirror array using standard, easily available and cheap technologies.

ANSYS program was used for simulation of mechanical properties of designed structure. Mechanical properties of torsion springs were modelled using formulas for torsion description of silicon structure.

We calculated the electrostatic force between the top (micromirror) and bottom electrodes and tried to find the compromise for the best size of micromirror, the biggest deflection angle of micromirror, and voltage between electrodes.

The electrostatic micromirror was fabricated using the Multi-User MEMS Processes. The electrostatically actuated micromirror was constructed using thin surface of micromachined polysilicon film on a silicon wafer.

**Keywords:** Micromirror, modeling, electrostatic, microsystems, optical

## 1 DESIGN OF ELECTROSTATIC MICROMIRROR ARRAY

We designed and simulated an electrostatic optical micromirror array, using a three-layer Polysilicon Surface Micromachining Process. During the design, we proceeded from the assumption that the applied technology was available and inexpensive.

The micromirror on Figure 1 is driven by electrostatic actuation. The phase of light reflected in the micromirror can be altered if the micromirror is pulled down towards the substrate. The top electrode is the centre area of the micromirror supported by the flexures. The bottom electrode is made either from Polysilicon - Figure 1 or the substrate. If the bottom electrode is the substrate, a thin film layer of silicon nitride isolates the electrodes.

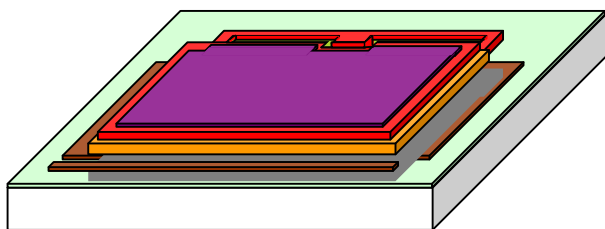

Figure 1: The polysilicon micromirror – bottom electrode is from polysilicon

The mirror is a moveable plate, while the access line underneath is a fixed plate. The capacitor electrodes must never touch each other, while the tip of the moving mirror touches the fixed level at a landing pad, which is conductive as well and kept at the same potential as the mirror. This is required in order to prevent a charge collection in the area of contact, if this should be an isolator. This points to one of the drawbacks of electrostatic actuators; the possible collection of charges in isolating parts, which may completely destroy the function of the device.

### 1.1 Modelling of Micromirror using Standard Mechanical Model

The standard mechanical model with the Newton equations was used for the design of the mechanical properties of the electrostatically actuated micromirror.

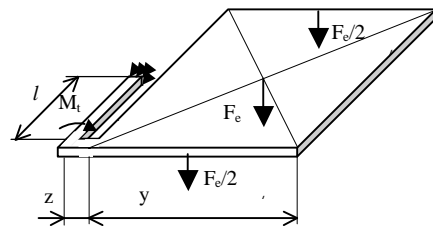

Figure 2: Micromirror with one torsion

Figure 2 shows the micromirror with one torsion spring. According to this figure the torque is

$$M_t(d) = \frac{F_e(d)}{2} \left( \frac{y}{2} + z \right) \quad (1)$$

where  $F_e$  is the electrostatic force and  $d$  is the separation distance between micromirror electrodes. For  $z \ll y$  can be used  $z = 0$ .

The system (the micromirror and torsion spring) is described by the equation:

$$M_t(d) = I \frac{d^2 \mathbf{a}}{dt^2} + z \frac{d \mathbf{a}}{dt} + D \mathbf{a} \quad (2)$$

where the first element represents the torsion acceleration of the system, second represents the losses of the system and  $D \mathbf{a}$  is the moment of the torsion spring. If the micromirror is in a vacuum, the losses will be near zero.

## 1.2 Modeling of Micromirror Using Electrical Equivalent Network

Building the equivalent network consists of the subdividing of the complete device structure into lumped elements. Each element is then described on the basis of analogies between relevant physical parameters of the dominating phenomenon and electrical parameters.

Each lumped element has a mechanical impedance, which is defined as the pressure drop to flow-rate ratio. This similarity appears clearly when we write the equation governing a mechanical system:

$$F = m \frac{dv}{dt} + \mathbf{x}v + k \int v dt, \quad (3)$$

where  $F$ ,  $m$ ,  $\mathbf{x}$ ,  $k$  and  $v$  are respectively the force, mass, friction coefficient, stiffness and velocity. This equation can be rewritten in the form:

$$M = I \frac{dw}{dt} + \mathbf{z}w + D \int w dt, \quad (4)$$

where  $M$ ,  $I$ ,  $\mathbf{z}$ ,  $D$  and  $w$  are respectively the torsion moment, mass moment inertia, friction coefficient, stiffness and torsion velocity. It is similar to that of an electrical series RLC circuit:

$$v = L \frac{di}{dt} + Ri + \frac{1}{C} \int idt, \quad (5)$$

where  $v$ ,  $L$ ,  $R$ ,  $C$  and  $i$  are respectively the voltage, inductance, resistance, capacitance and current. A complex mechanical device can then be modelled with an equivalent network by linking lumped elements in accordance to Kirshoff's laws adapted to mechanical system, the total mechanical moment taken around any closed loop is zero.

On the basis of the presented method of modelling, an equivalent electrical model of electrostatically actuated micromirror was built [1]. It is depicted in Figure 3.

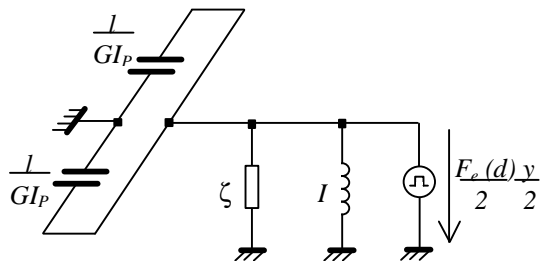

Figure 3: Equivalent circuit of an electrostatically actuated micromirror

For this model we can write:

$$v(d) = L \frac{di}{dt} + Ri + \frac{1}{C} \int idt = I \frac{di}{dt} + \mathbf{z} i + 2 \frac{GI_p}{l} \int idt \quad (6)$$

where  $v$  is the voltage (or the torsion moment),  $i$  is the current (or the torsion velocity),  $I$  is the mass moment inertia of micromirror plate,  $\mathbf{z}$  is the coefficient representing the losses of gas (air) around the micromirror (for micromirror in a vacuum  $\mathbf{z} \approx 0$ ),  $\frac{l}{GI_p}$  is stiffness of the

torsion spring used for the fixing of the micromirror. The moment of inertia is the rotational equivalent of mass in its mechanical effect, that is, the resistance to a change of state (a speeding up or slowing down) during rotation.

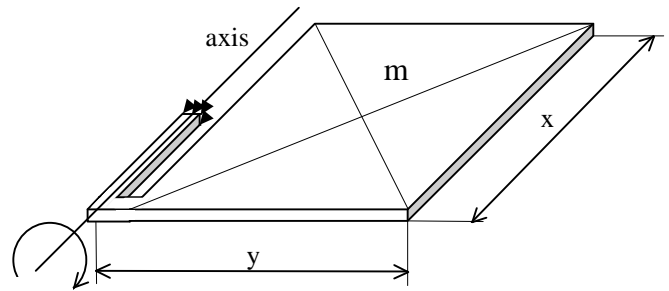

Figure 4: Micromirror plate with torsion spring and axis

For the micromirror plate the moment of inertia is:

$$I = \frac{1}{3} y^2 m, \quad (7)$$

where  $m$  is the total mass of the micromirror plate – Figure 4. According to the equation (4), (6) and Figure 3, the equivalent model of the micromirror in a vacuum is described by the equation:

$$v(d) = \frac{1}{3} y^2 m \frac{di}{dt} + 2 \frac{GI_p}{l} \int idt. \quad (8)$$

Now the micromirror can be solved like a parallel LC filter. For example, for the resonant frequency of the micromirror, we can use the Thompson equation:

$$f_0 = \frac{1}{2p\sqrt{LC}} = \frac{1}{2p\sqrt{\frac{2y^2ml}{3GI_p}}} \quad (9)$$

## 2 RESULTS ACHIEVED

For the mechanical simulation of micromirror, we used ANSYS program for finite element analysis and design. The electrostatic force between the top (micromirror) and bottom electrodes is calculated for a

micromirror with a distance of 2 mm (micromirror is a sandwich of Poly 1 and Poly 2) and for a distance of 2.75 mm (only Poly 2 is used for the micromirror). Input structure of meshed micromirror in in Figure 5.

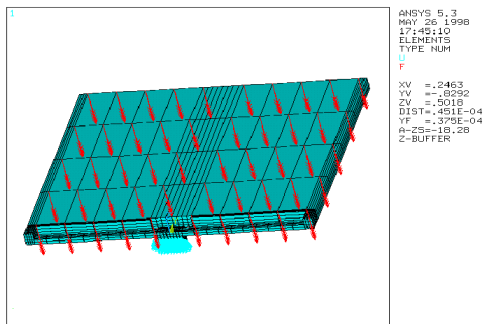

Figure 5: Input structure of meshed micromirror

The geometrical size of the micromirror is in Figure 6. With this, we try to find the compromise for the best size of the micromirror, the biggest deflection angle of the micromirror (dilatation could be 2 μm or 2.75 μm – MUMPs technology limitation), and voltages between electrodes. The theoretical maximum dilatation for the square micromirror is shown in Figure 7.



Figure 6: The geometrical size of micromirror

According to simulation, we consider the square micromirror size 70x70 μm (the sandwich of Poly 2 + metal and the sandwich of Poly 1 + Poly 2 + metal) and 80x80 μm (Poly 2 + metal) to be optimal. The detail simulation of the micromirror (the sandwich of Poly 1 + Poly 2 + metal) is shown below [2].

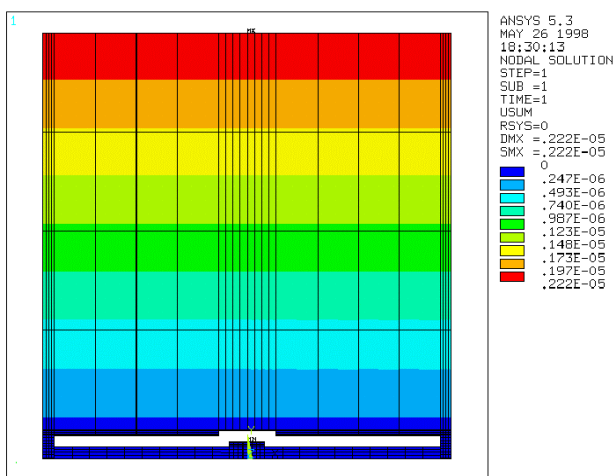

Figure 7: Dilatation of micromirror 70x70 μm (top view)

Figure 7 presents a simulation of 70x70 μm micromirror (top view) dilatation from the sandwich of Poly 1, Poly 2 and metal. Between the mirror and the bottom electrode is 36 V (electrostatic force is  $4.16 \cdot 10^{-6}$  N). The distance between the mirror and the bottom electrode is 2 mm. The micromirror will be deflected by 2 mm because the maximum theoretical dilatation from the ANSYS simulation is 2.2 μm. The maximum internal stress for polysilicon is 760 Mpa, the maximum stress in the torsion spring is 153 MPa. The security coefficient for this spring is about 5 [3].

The devices used in this work are micromirrors fabricated as a micromirror array. Figure 8 presents a detailed layout of one micromirror. The micromirror is a sandwich of Poly 1, Poly 2 and metal (gold). The size of the micromirror is 70x70 μm. The micromirror is used as one segment of the micromirror array, which contains mesh 20x20 micromirrors. For easy micromirror addressing, mesh from polysilicon (Poly 0, Poly 1) is used, connected to pads. For easy oxide etching, every micromirror contains five random holes for the separation of Poly 1, Poly 2 and metal. The maximum separative distance between Poly (metal) is 30 μm. The holes are necessary as they secure subsequent release of structures. Five types of micromirrors (ten on both layouts) are used for the first design. The difference is between the types of micromirrors, their geometrical size and the type of the bottom electrode.

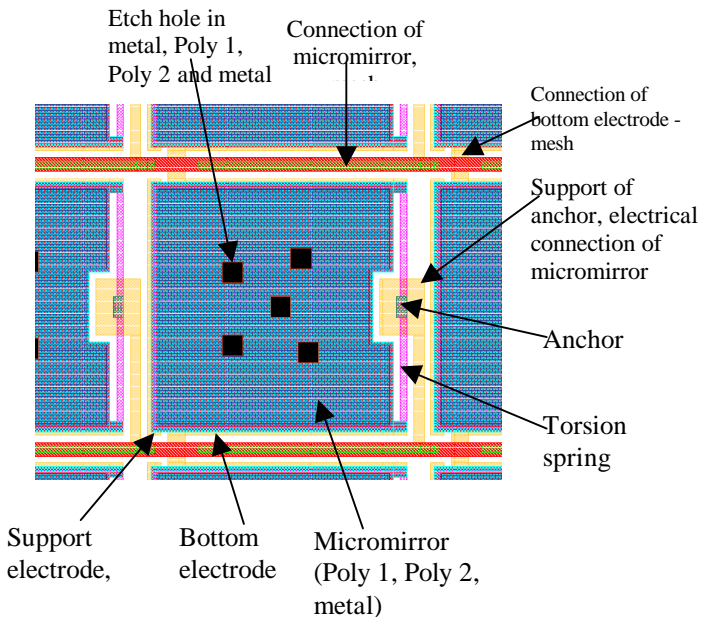

Figure 8: Layout of one cell of the micromirror array (micromirror is a sandwich of Poly 1, Poly 2 and metal)

Using MUMPs technology only, we fabricated and measured the designed electrostatically actuated micromirror arrays (in total 10 types of micromirror arrays). Figure 9 shows the entire micromirror array containing 20x20 micromirrors. The electrostatically actuated micromirror was constructed using surface micromachined polysilicon thin film on a silicon wafer. MUMPs offer three permanent layers of polysilicon and two semi-permanent

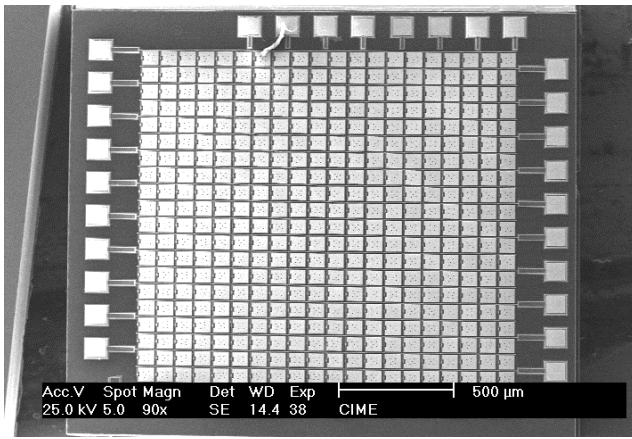

Figure 9: The micromirror array, a chip of five types of micromirrors

layers of phosphosilicate glass on a base layer of silicon nitride, derived from work performed at the Berkeley Sensors and Actuators Centre at the University of California [4]. The simulated and measured results of the chip are summarised in Table 1.

Type of Actuation	Electrostatic	
Used Technology	MUMPs	
Reflected Material	Gold	
Size of Micromirror	70x70 mm	
Size of Anchor	3x5 mm	
Micromirror Plate	Poly 1, Poly 2, Metal	Poly 2, Metal
Distance Between Electrodes	2 mm	2.75 mm
Simulated Parameters		
Voltages Between Electrodes	36 V	47 V
Dilatation Angle of Micromirror	1.64°	2.25°
1 <sup>st</sup> Resonant Frequency	42529 Hz	60407 Hz
Reflectivity (Angle of Beam 45°)	42.8%	
Measured Parameters		
Voltages Between Electrodes	34 V	45 V
Dilatation Angle of Micromirror	1.76°	2.35°
Maximum Frequency (Vacuum ~5Pa)	26 kHz	31 kHz
Maximum Frequency (Air)	6 kHz	9 kHz
Tested Cycles	100 hours, 8·10 <sup>8</sup> cycles	
Measured Reflectivity (Angle of Beam 45°)	50%	
Penetration of Reflectivity	>70%	

Table 1: The parameters of the micromirror and the micromirror array

### 3 CONCLUSIONS

The main objective of the project was to design a moveable micromirror array with the most optimal dependence of the optically active area, the deflection

angles and the micromirror power consumption, while keeping the cost of the chip as low as possible. The ANSYS program was used for the mechanical simulation.

The micromirror array (20 x 20 micromirrors) use an electrostatically actuated principle. The array is designed using the Three Layer Polysilicon Surface Micromachining Process (MUMPs technology). Each micromirror has two torsion springs and the size of the reflected plate is 70x70 mm. The penetration of the reflected micromirror array is about 70%. The micromirror array is addressed by 36 pads that are connected to the top and bottom electrodes (mesh). Potential (36 V) connected between electrodes is used for the actuation of micromirror. For the first step, we designed 20 types of micromirrors (two layouts), which differ in geometrical sizes and thickness of the micromirror plates. The dilatation angle of the micromirror is 1.7 or 2.3 degrees depending on the type of the micromirror.

We used a new type of fixing of the micromirrors in order to, at most, enlarge the reflective surface at the expense of the connection and addressing of the micromirrors. The chip was practically executed and measured and the measured mechanical and optical results were compared with the results of the simulations. Only minor differences were found.

For the best type of micromirror array, it is necessary to use a technology, which combines the electrical parameters of the CMOS technology (for electronics) and the mechanical parameters of the MUMPs technology (for micromirror plates), e.g. SUMMiT V technology. The Sandia Ultra-planar, Multi-level MEMS Technology for Five levels (SUMMiT V) of the fabrication process is a five-level polycrystalline silicon surface micromachining process (one ground plane/electrical interconnect and four mechanical layers) [5].

### Acknowledgement

This research has been supported by the Ministry of Education, Youth and Sports project No. VS97046. At present, the research is supported by the following research programme of the Czech Technical University in Prague: No. J04/98:210000015 "Research of New Methods for Measurement of Physical Quantities and Their Application in Instrumentation"

### REFERENCES

- [1] M. Huja, Micromirror Array. Ph.D. Thesis, Prague 1999.
- [2] M. Huja, Micromirror Driven by Electrostatic Actuation, 8<sup>th</sup> Vienna Optrode Workshop, Book of abstracts. p.49-50, Prague 1998.
- [3] M. Husak at al., A Design of Microsystem Structure, a Research Report, Prague 1999 (in Czech).
- [4] MEMS Technology Application Centre, Three-Layer polysilicon Surface Micromachining Process, <http://mems.mcnc.org>
- [5] Sandia National Laboratories, <http://www.mdl.sandia.gov/micromachine/techinfo.html>