

SOFC/ZEBRA Hybrid System

M. Ferraro*, G. Napoli, F. Sergi, G. Brunaccini, G. Dispenza, V. Antonucci

Institute of Advanced Technologies for Energy “Nicola Giordano”,
National Council of Research - Salita S. Lucia sopra Contesse, 5 - 98126 Messina, Italy

* tel +39.090.624236, fax +39.090.624247, email: marco.ferraro@itae.cnr.it

ABSTRACT

Solid Oxide Fuel Cell (SOFC) based combined heat and power systems are considered a promising technology for residential purposes. Meantime, Distributed Energy Resources (DER) installations are typical applications that need energy storage and fit well with the features of ZEBRA battery. The objective of this work was to develop an efficient hybrid system able to deliver the power requirement, combine energy storage and ensure durable operation. The integration of a SOFC system with one or more storage devices allows, in fact, to use the inherent advantages of each system. A specific control algorithm was developed for utilizing the SOFC system as a base power source and ZEBRA battery as a complementary source. The developed demonstrator is a Combined Storage Heat and Power (CSHP) system.

Keywords: fuel cell, batteries, hybrid system, smart grid

1 INTRODUCTION

Hybrid Systems are co-operating units able to generate electricity with different energy sources (and in certain cases heat). The management of energy is performed by the use of power converter device. The main aim of hybrid systems is to supply off grid communities but they can also operate connected to the grid, allowing to administrate the energy flows. In our opinion this type of plants are a good way to increase availability and flexibility of power supply systems and allows to combine several primary renewable or non renewable energy carriers.

The adoption of this concept of hybrid system which combines both fuel cell and energy storage

units, can offer a suitable solution improving energy grid reliability, availability, and cost reduction.

Several examples of hybrid systems can be found to improve performance and efficiency of distributed generation devices [1]:

- SOFC combined with a gas turbine or microturbine;
- Stirling engine combined with a solar dish;
- Wind turbines with diesel backup storage;
- Engines combined with energy storage devices such as flywheels or batteries.

The storage systems, can play a key role in this context. The realization of a hybrid system, capable of connecting production and storage devices on one hand, and to manage and control the energy and its exchange on the other hand, represents the synergy of some innovative technologies but already commercially available and meet ever growing power demand.

Compressed air pump, pump storage systems, innovative secondary batteries, supercapacitors are some of the technologies that could be used.

Recent works and CNR-ITAE activities have demonstrated possible and interesting synergies between two electrochemical devices allowing high efficiencies and flexibility thanks to electrical and thermal integration: high temperature batteries and high temperature Fuel Cells [2-4].

2 ZEBRA AND SOFC TECHNOLOGY

High temperature batteries such as sodium sulfur (NaS) and Sodium nickel chloride (NaNiCl) can cycle on a daily basis and have

useful operating life (10-20 years). These systems have no emissions, permit quiet operation and have been designed for charge/discharge duration (designed for automotive and transportation).

ZEBRA (Na-NiCl) high temperature batteries (270-350°C) exhibit an energy density of 120Wh/kg which is 3-4 times higher than conventional lead-acid batteries and 2-3 times higher than nickel-metal hydride batteries [5].

For instance, FIAMM Sonick battery, to sustain operation during start-up and stand-by, is provided with internal electric heaters to achieve and maintain internally the working temperature of 275 °C.

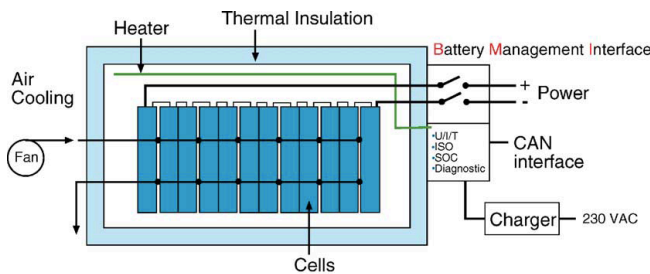

Figure 1 Fiamm SoNick battery layout

The FIAMM SoNick batteries are commercial products, main drawbacks, that limits their use, are linked with the thermal management (Table 3).

The battery (48TL80-NV) used for tests and subsequent integration with the SOFC system has the following features (Table 1):

FIAMM Sonick battery (48TL80-NV)	
Features	Values
Nominal Voltage	48 Vdc
Operating Voltage range	42 to 56 Vdc
Nominal Capacity	80 Ah
Nominal Energy	4 kWh
Maximum Discharge Current	50 A
DC Bus Voltage Range	54 - 57 Vdc
Internal Low Voltage Disconnect	40 Vdc
Communication Port	RS232
Operating Ambient Temperature	-20 to +60 °C
Operating temperature	270-350°C

Table 1 Fiamm SoNick 48TL80-NV features

A SOFC (Solide Oxide Fuel Cell) μ -CHP unit is an electrochemical device, operating at a high temperature (700-900°C), consisting of an oxide

electrolyte between an anode and a cathode, able to convert the chemical energy of fuel into electric energy and exhaust heat. SOFC systems fed with natural gas are 30-40 % efficient in converting fuel to electricity and in cogeneration applications overall efficiencies can be as high as 85 %.

At present, the state-of-the-art of SOFC technology is not yet at commercial level, only laboratory and niche market devices are ready. This delay with respect to other solutions is due to several still unsolved problems, but likewise numerous are the achievable advantages.

The main problems linked to the SOFC technology are showed in Table 2 and demonstrated also during tests of an innovative μ -CHP system developed by SOFCpower and Dantherm Power performed at CNR-ITAE.

However, a series of good features must be considered, the most evident are:

- high fuel conversion performance (that allows for compact size devices);
- capability of internal fuel processing (unlike other FC technologies, solid oxide does not need extremely pure hydrogen as a fuel);
- valuable vocation for Combined Heat and Power (CHP) by exploiting high temperature exhaust gases (this leads to high overall efficiency systems through the reuse of heat waste).

Moreover, as other fuel cell technologies, SOFC benefits from direct electrochemical conversion of the supplied fuel into electrical energy without combustion and moving parts.

As consequences, they have high electrical efficiency (compared with traditional internal combustion engines), low noise level (only the auxiliary devices, like fans or blowers, have moving parts) and negligible (or low) emissions of environment pollutants.

SOFCs are good energy sources to provide reliable power at steady state; however, due to their slow internal electrochemical and thermodynamic characteristics, they cannot respond to electrical load transients as quickly as desired.

SOFC system	
Characteristics	Values
Nominal Voltage (after DC/DC)	48 Vdc
Operating Voltage range	25 to 44 Vdc
Feeding Gas	desulph. NG
Nominal Power	0.5 kW
Maximum Discharge Current	50 A
DC Bus Voltage Range	44 - 57 Vdc
Internal Low Voltage Disconnect	44 Vdc
Communication Port	RS232
Operating Ambient Temperature	0 to +60 °C
Operating Temperature	750-780°C
Exhaust Temperature	300-370°C

Table 2 μ -CHP features



Figure 2 SOFC system (SOFCpower/Dantherm Power) and Fiamm SoNick 48TL80-NV during tests at CNR-ITAE

Asterix SOFC drawbacks	FIAMM SoNick as solution
Not able to load following	More than 1,000 cycles (automotive technology)
FIAMM SoNick drawbacks	Asterix SOFC as solution
Preheating needed to get battery up to the 270°C operating temperature (about 20 hours from cold)	Heat co-production from fuel Start-up time: 7 hours
Uses 14% of its own capacity per day to maintain temperature when not in use	Heat co-production at 350°C recoverable during normal operation
Thermal management needed	Thermal management needed

Table 3 Summary of drawbacks and synergies between ZEBRA batteries and SOFC μ -CHP

3 RESULTS

Derived from the previous results, a demonstrator based on SOFC system and ZEBRA battery was developed.

The SOFC system operates at constant power and the “gap” between load and SOFC power is fulfilled by the energy storage system (ZEBRA battery), the surplus of energy allows the charge of the battery (Fig.3).

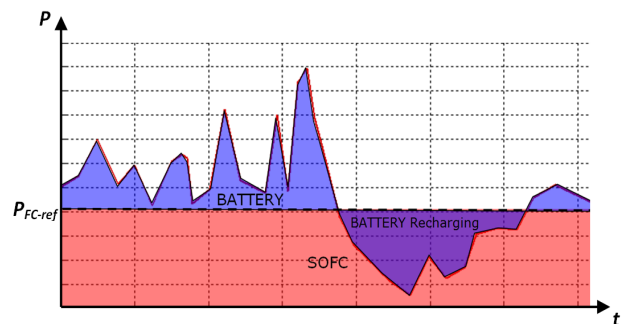

Figure 3 Example of expected power curves during operation

The system took into account the slow dynamics of SOFC technology and divided the required power through a control policy implemented by a dc/dc converter connected as shown in Fig.4.

This type of control allowed to regulate the power sharing between the fuel cell and the battery in order to maximize the advantages of each component.

SOFC was fed both with natural gas operating at 780°C with 350°C exhaust stream temperature. Meantime the battery operated at 275 °C allowing the heat recovering with the SOFC technology. The results of test conducted (load following) are shown in Fig. 5.

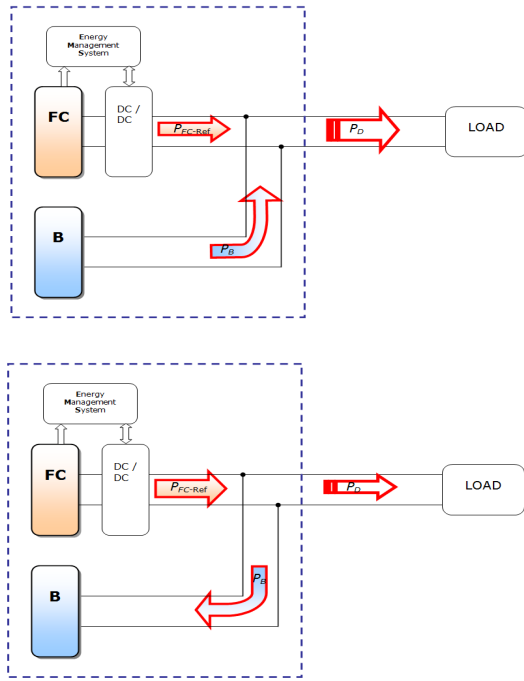

Figure 4 Operating modes of the demonstrator. Battery discharge and charge

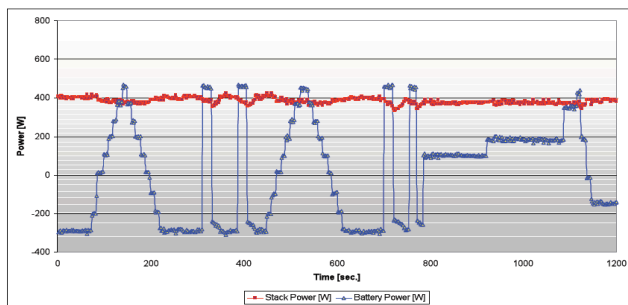

Figure 5 SOFC/ZEBRA hybrid system electrical behaviour

First results on demonstrator encourage the development of hybrid systems based on SOFC/ZEBRA. Implementing appropriate control strategies, through the use of dedicated power converters, should be possible to integrate, at dwelling level, different distributed energy sources, like wind and photovoltaic, with a μ -CSHP (Combined Storage Heat and Power) system able to manage different energy source and their flows from and towards the grid (Fig. 6).

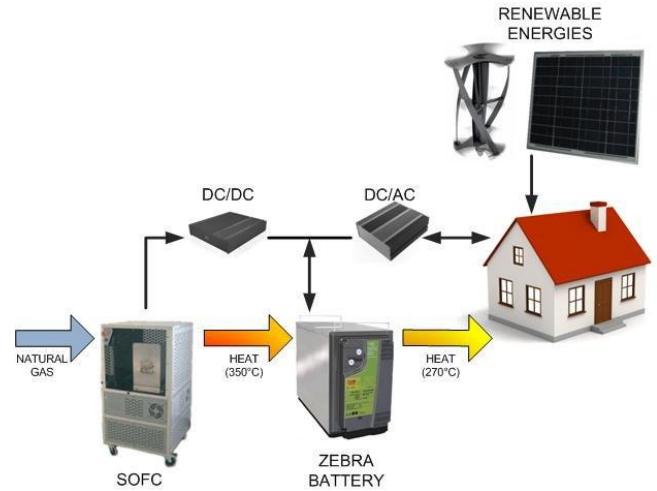

Figure 6 Scheme of integration between the μ -CSHP developed and RWE at dwelling stage

REFERENCES

- [1] Jozef Paska, Piotr Biczal, Mariusz Kios
Renewable Energy 34 (2009) 2414–2421
- [2] D.J.L. Brett, P. Aguiar, N.P. Brandon, R.N. Bull, R.C. Galloway, G.W. Hayes, K. Lillie, C. Mellors, C. Smith, A.R. Tilley
Journal of Power Sources 157 (2006) 782–798
- [3] D.J.L. Brett, P. Aguiar, N.P. Brandon
J. Power Sources 163 (2006) 514–522
- [4] P. Aguiar, D.J.L. Brett, N.P. Brandon
Journal of Power Sources 171 (2007) 186–197
- [5] Cord-H. Dustmann
Journal of Power Sources Volume 127, Issues 1-2, 10 March 2004, Pages 85-92.