

Maximum Power Point Tracker Controlling PV Converter: Research and Development Study

Mariya Dinkova, Prof ,PhD ^{*} ; Taner Nedzhip, Eng ^{**} ,

^{*} University of Food Technologies, 26, Maritza Blv.,
4002 Plovdiv, Bulgaria, brightenbg@yahoo.com

^{**} Dmatek Bulgaria Ltd, 13, Samara Str., 4003 Plovdiv, Bulgaria, taner_n@abv.bg

ABSTRACT

This paper presents a software-developed Maximum Power Point Tracker (MPPT) algorithm for the control of Photovoltaic (PV) DC-DC and DC-AC converters. The proposed algorithm was realized with an 8-bit microcontroller unit (MCU) and it represents a part of a general control algorithm of the grid-connected PV inverter. The new MPPT algorithm is obtained as a result of the combination of two known algorithms: the perturb and observe (P&O) one and the constant voltage (CV) one. This combined algorithm leads to a more dynamic and stable operation of the MPPT.

The particularity of this combining algorithm is the necessity of voltage temperature compensation (CT) in an open circuit PV mode easily attained with the help of contemporary temperature sensors.

In conclusion, we may say that our combining algorithm of MPPT is suitable for application with PV converters (DC-DC and DC – AC), powered by PV modules feeding power not only to the grid but also to “infinite” DC load, such as battery (in charging mode).

Keywords: PV, photovoltaic, MPPT, grid-connected inverter, power electronics

INTRODUCTION

The growth of renewable energy technologies have been exponential in the last decade. Of all renewable technologies it is solar energy that has gained most popularity for its application to not only industry but homes alike. Active solar technologies use the photovoltaic (PV) cell [1] to convert solar energy into electric energy.

PV modules (array) are built by connecting several PV cells in a proper way thus deriving bigger output power. The output energy of PV module is DC and can charge directly batteries or other DC loads. When PV array supplies AC loads then its energy is converted by DC- AC converters.

The conversion efficiency of the silicon (Si) PV cells is very low (about 14-16%). Thus the necessity for using

special circuit and software methods to derive maximum power from the solar arrays

The main purpose of this study is to develop and investigate an improved algorithm which helps to realize maximum power point tracking unit combining two already known algorithms.

1 COMPONENTS AND BASE CHARACTERISTICS OF PV MODULE

A PV module is built from a large number (36 or 72) of properly connected PV cells. The simplified equivalent circuit of a single PV cell is shown in fig.1a [2,3].

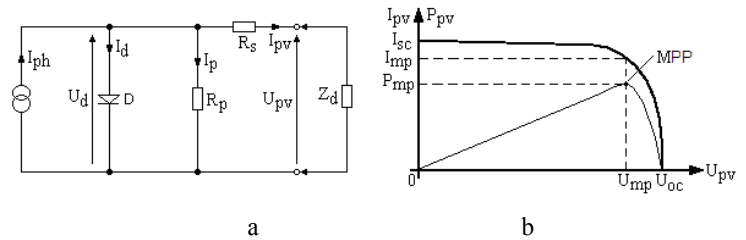

Fig.1 An equivalent circuit (a) and a PV cell I-V curve(b) .

The output current equation describing the single PV cell equivalent circuit – in fig.1a (and ignoring current flowing through the parallel resistance R_p) is as follows [2, 3, 5] :

$$I_{pv} = I_{ph} - I_s \left\{ \exp \left[\frac{q}{AkT} (U_{pv} + I_{pv} R_s) \right] - 1 \right\}, \quad (1)$$

where I_{ph} is the photocurrent, I_s is the reverse saturation current, q is the electron charge, A is the correcting coefficient, k is Boltzman’s constant, T is the PV cell’s temperature and R_s is the series resistance.

A sample PV cell I-V curve is shown in fig.1b, where I_{sc} is the short circuit photocurrent and U_{oc} is the open circuit voltage.

1.1 Maximum Power Point Tracker (MPPT)

There is a point on the I-V curve where maximum power P_{mp} is achieved and this point is named Maximum Power Point (MPP). Its coordinates are current I_{mp} and voltage U_{mp} . The purpose of Maximum Power Point Tracker (MPPT) is to maintain the PV module's operating point close to MPP by regulating the converter input impedance.

Many MPPT algorithms have been proposed in the literature [3,4,5], but the most widely-used are four: the algorithm of Perturb and Observe (P&O), the algorithm of Incremental Conductance (IncCond), the algorithm of Constant Voltage (CV) and the algorithm of Constant Current (CC).

P&O and IncCond algorithms are adaptive and their detecting MPP accuracy is independent of PV module parameters. CV and CC algorithms on the other hand are approximate and their tracking MPP accuracy depends on solar irradiance and PV module temperature.

The P&O algorithm operates by periodically perturbing (i.e. incrementing or decrementing) the PV module voltage (or current) and keeps track of the sign of output power difference before and after perturbing [3,4]. Depending on the power converter topology, only a voltage sensor might be needed as shown in [5]. The oscillation that appears close to MPP can be minimized by reducing the perturbation step size, however this slows down the MPPT and reference [6] proposes a two-stage algorithm that offers faster tracking in the first stage and finer tracking in the second one. The advantages of P&O algorithm are simplicity and easy implementation.

The IncCond algorithm is based on the PV source incremental conductance as a method for tracking the MPP [3,4]. The PV output voltage can be regulated by comparing the instantaneous conductance I_{pv}/V_{pv} to the incremental conductance dI_{pv}/dV_{pv} . The sign of their sum indicates the correct direction of tracking MPP. This algorithm is more effective than P&O algorithm but at the cost of numerous complicated mathematical calculations.

The CV and CC algorithms maintain fixed operating point (holding it constant under any condition), where the

PV voltage or current are closest to U_{mp} and I_{mp} . The relationship between U_{mp} and U_{oc} and the relationship between I_{mp} and I_{sc} are expressed by the following equations [4,5]:

$$U_{mp} = k_U \cdot U_{oc}; I_{mp} = k_I \cdot I_{sc} \quad (2),$$

where k_U is a coefficient between 0,75 and 0,8, and k_I is a coefficient approximately equal to 0,9.

References [7,8] suggest a combination of some of the above mentioned algorithms.

1.2 MPPT block diagram

The block diagram of a grid-connected PV inverter is shown in fig.2. The main part of it is a MPPT which is one of the inverter driver circuit inputs. The MPPT output voltage U_{MPPT} is multiplied by the current inverter reference (in the inverter driver circuit), thus maintaining the operating point close to MPP. The MPP tracker adjusts the inverter duty ratio D (using PWM) and hence the inverter input impedance so that the PV module operates at the maximum power point.

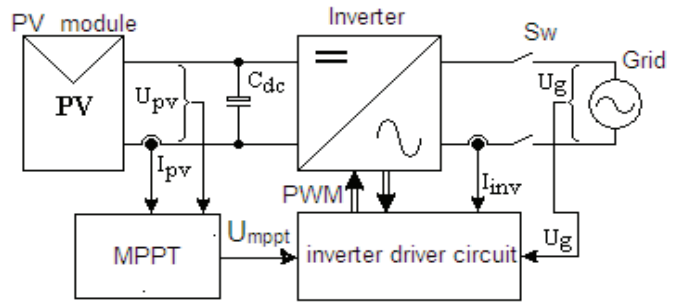

Fig.2. PV grid-connected inverter block diagram

In the present case MPPT algorithm is realized as software, combining two known algorithms: CV and P&O. In this way a more rapid and stable MPPT work is achieved. A more detailed MPPT block circuit implementation is shown in fig.3.

The two separate parts of the combining algorithm are shown in fig.3: the algorithm of perturb and observe (P&O) and the algorithm of constant voltage (CV).

The MPPT output voltage U_{MPPT} is switched to the inverter driver circuit (fig.2). The PV module open circuit voltage U_{oc} is measured before starting the inverter. The voltage U_{mp} in the MPP is calculated in equation (2). After that the inverter CV part of the algorithm is started. It aims at establishing a PV output voltage close to MPP calculated voltage value. The PV module temperature T_{pv} for temperature compensation (CT) of ($\Delta U_{oc}/\Delta T \approx -2,2mV/^\circ C$) is also measured in this algorithm.

After reaching preliminarily given voltage value U_{mp} the second mode (based on P&O algorithm) starts. This algorithm is adaptive and tracks more precisely MPP.

Once PV module voltage goes out of MPPT range (covered by P&O) the CV algorithm starts. CV algorithm restores the

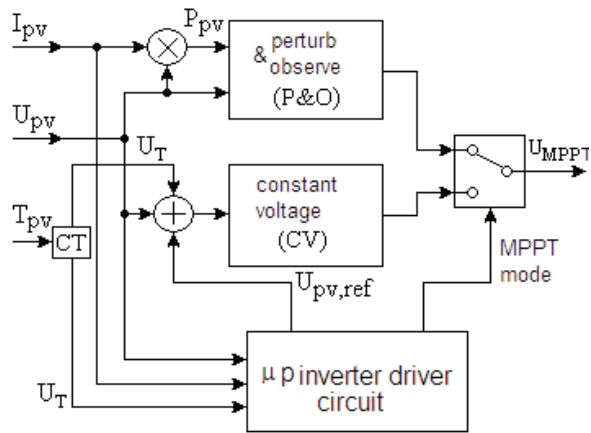

Fig.3 MPPT block diagram

PV module output voltage close to MPP and, again, adaptive P&O algorithm starts, etc.

2 EXPERIMENTAL RESULTS

A PV system is built to test the algorithm. The developed system consists of two PV modules SEM70 in series, a grid-connected single phase inverter (full bridge circuit implemented with IGBT) with output transformer and an inverter driver circuit. The MPPT algorithm and full inverter driver circuit are realized with PIC 18F2520. The developed combining MPPT algorithm is tested for dynamics by sharp change of solar irradiance (by solar simulator) and for MPP detecting accuracy by comparison of an automatic and manual mode. Fig.4 represents the reactions of MPPT to the two modes when the irradiance harshly increases.

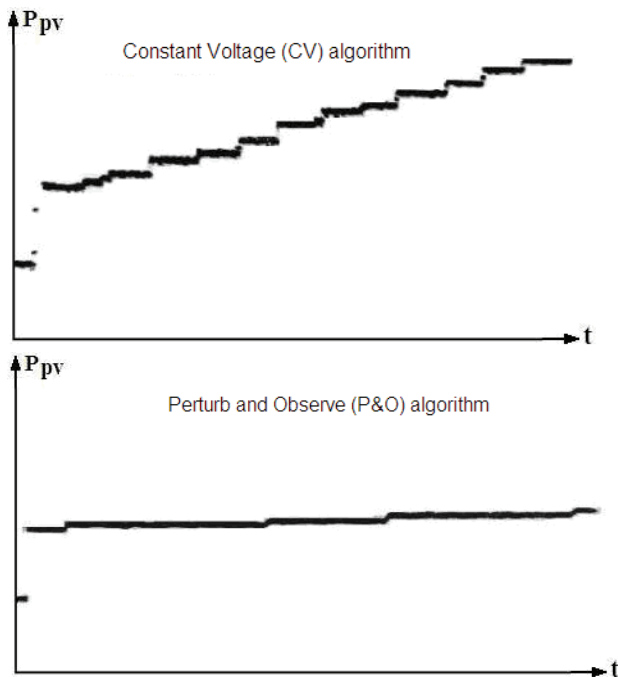

Fig. 4 Reaction of MPPT when the irradiance harshly increases

MPPT reactions when the irradiance harshly decreases are shown in fig. 5.

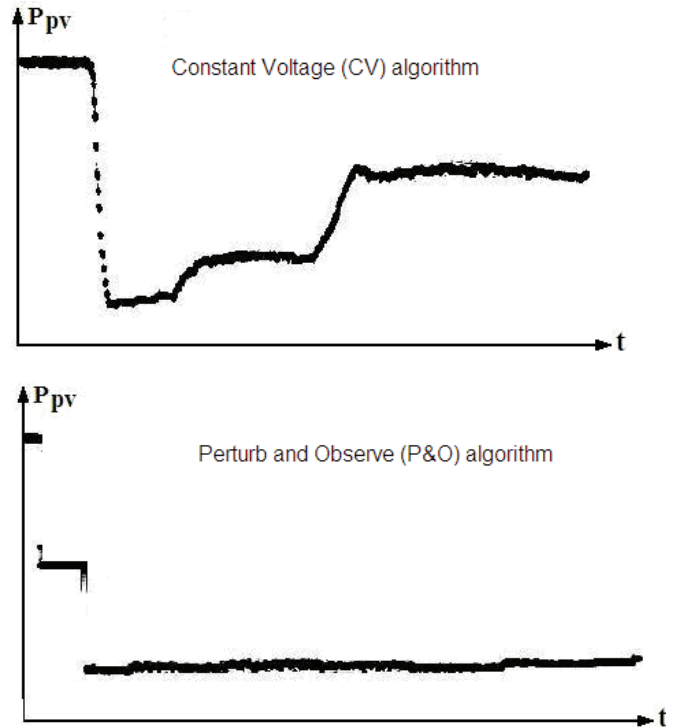

Fig. 5 Reaction of MPPT when the irradiance harshly increases.

Fig.6 shows a PV module I-V curve with three MPP: MPP1 is achieved manually, MPP2 is achieved by CV algorithm and MPP3 is achieved by P&O algorithm. The comparison of CV and P&O algorithm accuracies is made in relation to MPP1.

The derived power in the three MPP is: $P_{mp1} = 56,96W$ (for MPP1), $P_{mp2} = 52,32W$ (for MPP2) and $P_{mp3} = 55,97W$ (for MPP3). Thus, the MPP detecting accuracy is 0,92 for CV algorithm and 0,98 for P&O algorithm.

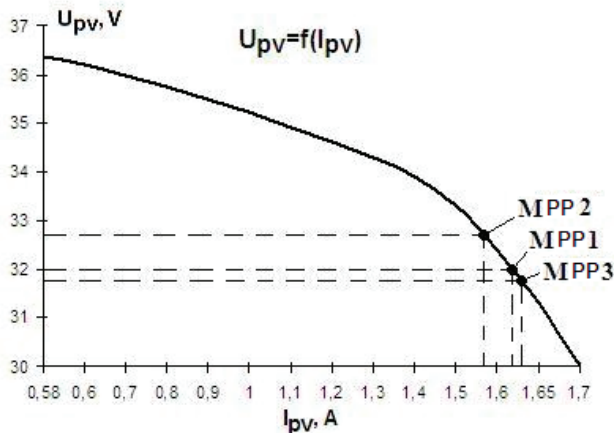

Fig.6. Experimental PV module I-V curve

CONCLUSIONS

Based on the presented experimental results the following conclusions may be drawn: The combining algorithm leads to a more dynamic and stable operation of the MPP tracking without compromising its accuracy.

The particularity of this combining algorithm is the necessity of voltage temperature compensation (TC) in an open circuit PV mode easily attained with the help of contemporary temperature sensors.

The combining method of MPPT is suitable for application with PV converters (DC-DC and DC – AC), feeding power not only to the grid but also to ‘infinite’ DC load, such as battery in charging mode.

REFERENCES

- [1] Димитров, Д., Лазаров, В., и колектив. *Възобновяеми източници на енергия*. София, Технически университет, 1999.
- [2] Koutroulis, E., Kalaitzakis, K., Voulgaris, N. C. Development of a microcontroller-based, photovoltaic maximum power point tracking control system. *IEEE Transactions of Power Electronics*, Vol. 16, No. 1, pp. 46-54, Jan. 2001.
- [3] Esram, T., Chapman, P. L. Comparison of photovoltaic array maximum power point tracking techniques. *IEEE Transaction on Energy Conversion*, Volume 22, Issue 2, Pages: 439-449, June 2007.
- [4] Hohm, D. P., Ropp, M. E. Comparative study of maximum power point tracking algorithms. *Progress in Photovoltaics: Research and Applications*, John Wiley & Sons, Ltd., 2002.
- [5] M. Veerachary, T.Senju and K.Uezaro, “Maximum power point tracking control of IDB converter supplied PV system”, in *IEE Proc. Rlect. Power Applicat.*, 2001, pp.494-502
- [6] K.Kobayashi, I.Takano, and Y.Sawada, “A study on a two stage maximum power point tracking control of photovoltaic system under partially shaded insolation

conditions”, in *IEEE Power Eng.Society GeneralMeeting*, 2003, pp.2612-2617

[7] Т.Неджип, “Разработка и изследване на регулатор на максимална мощност за управление на фотоелектрически преобразувател”, *Национална конференция “Електроника 2008”*, Сборник доклади, стр.225-230, София, 29-30 Май 2008

[8] R.Faranda, S.Leva, “ Energy comparison of MPPT techniques for PV systems”, in *WSEAS Transaction on Power Systems*, issue 6, vol 3, June 2008